

2010

RENICE X1 50mm mSATA SSD Datasheet

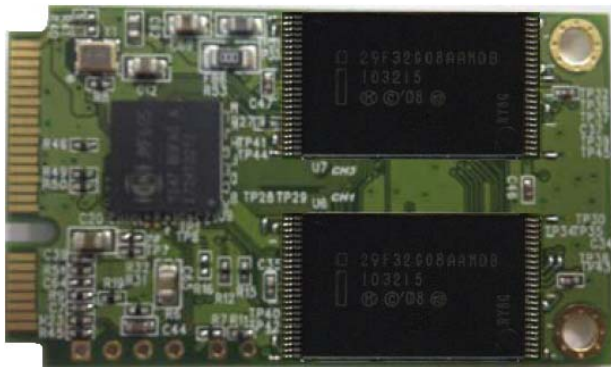

Shi Jian Lee

Renice Technology Co., Limited

2010-12-15

CATALOGUE

1. Introduction	3
1.1 Product Overview	3
1.2 Feature	3
1.3 Functional Block Diagram.....	4
1.4 Form Size	5
2. Pinout information	6
1) Pin Assignment	6
2) Connector Pin Signal Definitions.....	7
3. Power Specification	8
1) Operating Voltage :3.3V(±5%).....	8
2) Power Supply Voltage	8
3) Power Consumption(typical).....	8
4. Reliability Specification	8
5. SATA Interface Features	9
6. ATA Command Set	10
7. SMART.....	13
8. Buy Information	15
9. Product model of naming rule	15

1 Introduction

1.1 Product Overview

ReniceX1 MSATA SSD (Solid State Drive) is a high performance and high reliability storage device based on NAND Flash technology that designed to solve the bottleneck of computing system by traditional hard disk drives. ReniceX1MSATA SSD doesn't have a moving parts and it has a same host interface and same physical dimension with Hard Disk Drive, So it can be drop-in replaced with the hard disk drives without anything. With a high performance and low power consumption, ReniceX1MSATA SSD can be a good storage device for NB and Tabletop PC, ReniceX1 MSATA SSD purely consists of semiconductor devices and NAND flash memories, which give rugged features against shock and vibration use in extreme environment such as industrial PC an increased MTBF. Further more, ReniceX1MSATA SSD has highly advanced flash memory management algorithm to guarantee higher performance and data integrity

1.2 Feature

- Performance

- Sequentila Data Read:140-160MB/s

- Sequentila Data Write:30-150MB/s

- Access Time: 0.1ms

- Form factor: 50.95mmX10mmX1.65mm(LxWxH)

- Weight: <10g

- Interface standard: SATA

- Density:8GB,16GB,32GB,64GB,128GB(MLC:8GB~128GB,SLC:8GB~64GB)

- Input voltage: 3.3V (±5%)

- Commercial operating temperature range form 0 to +70°C

- Flash management algorithm: static and dynamic wear-leveling, bad block management algorithm

- Supports dynamic power management and SMART (Self-Monitoring, Analysis and Reporting Technology)

- Supports BCH ECC 8bits or 15bits in 512 bytes

- Supports NCQ

- Write endurance: >8 years @ 100GB write/ day (30GB SSD)

- Read endurance: unlimited

- Data retention: 10 years

- MTBF: 2,000,000 Hours

1.3 Functional Block Diagram

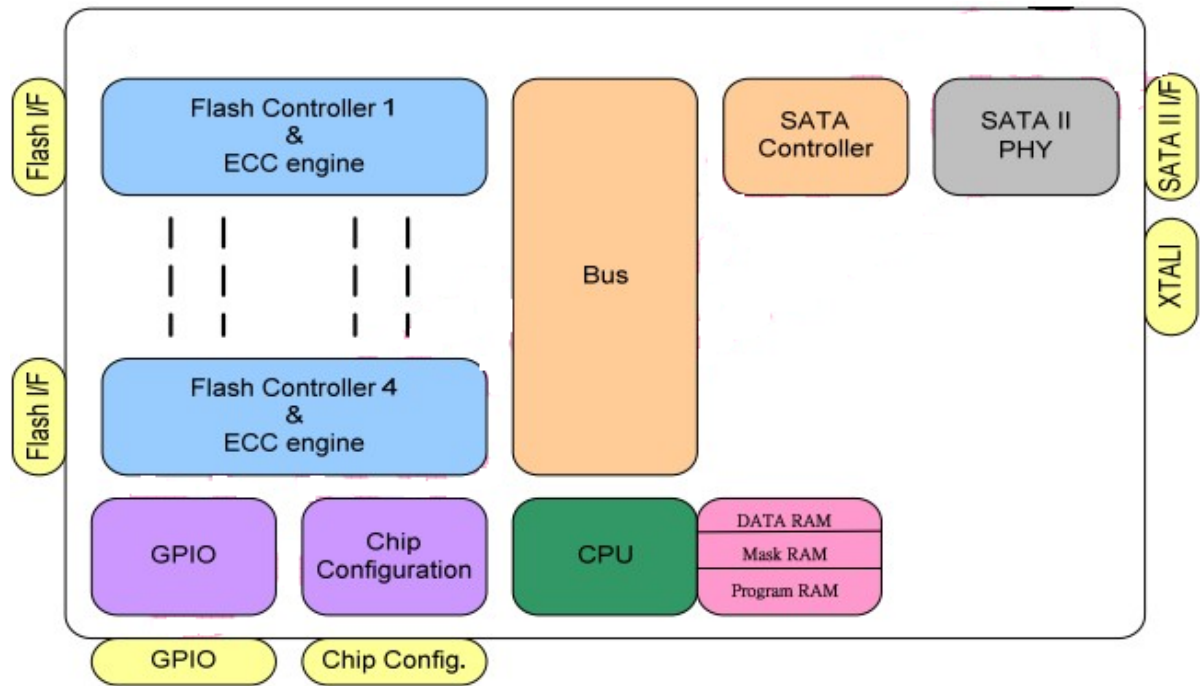

Figure 1.1: Functional Block Diagram

1.4 Form Size: 50.95mmX10mmX1.65mm(LxWxH)

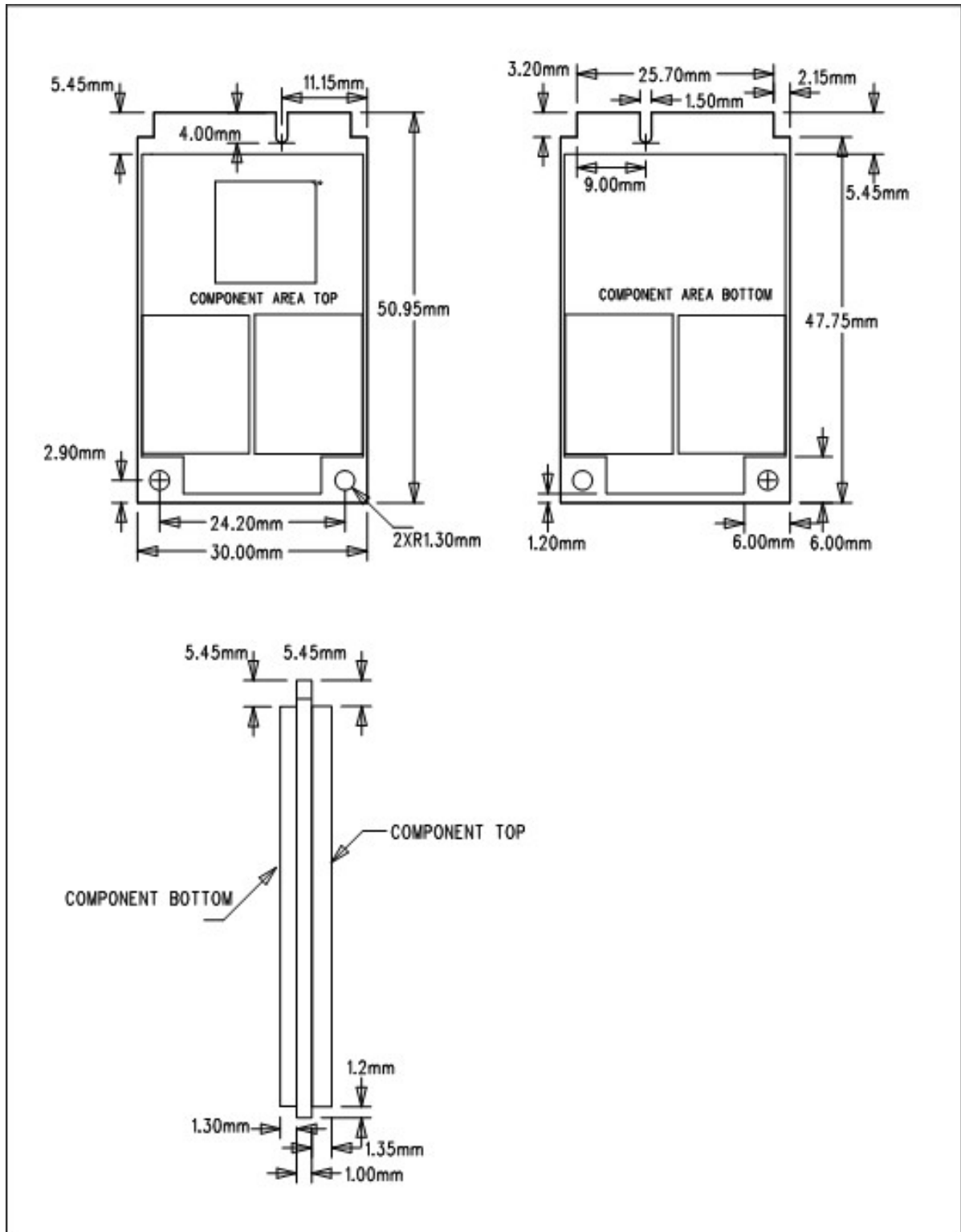

Figure1.2:form size

2Pin out information

1) Pin Assignment

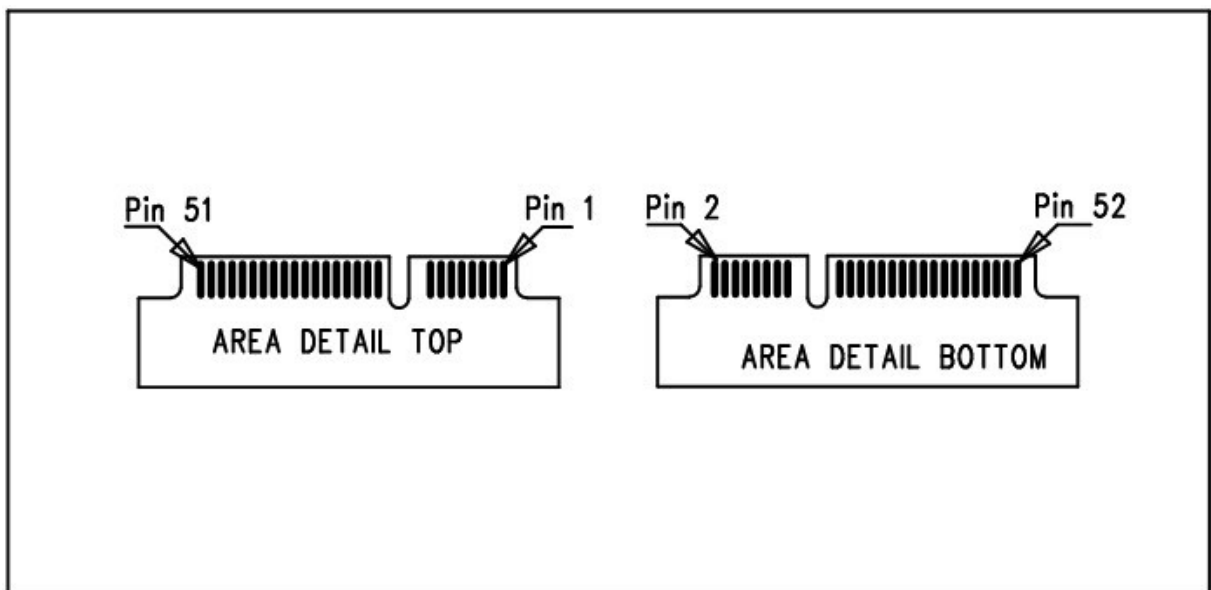

Figure .2-1:Pin Assignment

2)Connector Pin Signal Definitions

Table .2-2:Connector Pin Signal Definitions

Pin	Definitions	Pin	Definitions
P1	NC	P2	+3.3V
P3	NC	P4	GND
P5	NC	P6	NC
P7	NC	P8	NC
P9	GND	P10	NC
P11	NC	P12	NC
P13	NC	P14	NC
P15	GND	P16	NC
P17	NC	P18	GND
P19	NC	P20	NC
P21	GND	P22	NC
P23	SATA Differential TX+ based on SSD	P24	+3.3V
P25	SATA Differential TX- based on SSD	P26	GND
P27	GND	P28	NC
P29	GND	P30	NC
P31	SATA Differential RX- based on SSD	P32	NC
P33	SATA Differential RX+ based on SSD	P34	GND
P35	GND	P36	NC
P37	GND	P38	NC
P39	+3.3V	P40	GND
P41	+3.3V	P42	NC
P43	GND	P44	NC
P45	Vendor	P46	NC
P47	Vendor	P48	NC
P49	DAS/DSS	P50	GND
P51	Presence Detection	P52	+3.3V

3 Power Specification

1) Operating Voltage :3.3V(±5%)

2)Power Supply Voltage

1.0v for Core, 3.3V for NAND and Core.

3) Power Consumption(typical)

Operation (Read/Write) – 1.2W

Idle - 0.6W

Standby - 0.6W

Sleep(Partial/Slumber) - 0.6W/0.26W

4 Reliability Specification

Item	Features	
Temperature	Operating	Standard: 0°C ~ 70°C
Humidity	5-95%	
Vibration	20G(7-2000Hz)	
Shock	2,000G(@0.3ms half sine wave)	
MTBF	>2,000,000 hours	

5 SATA Interface Features

- . Seamless SATA interoperability
- . Plug-and-play field-proven SATA-v2.6-compliant interface
- . 3 Gbps / 1.5 Gbps signaling (auto-negotiated)
- . Native Command Queuing (NCQ) support
- . S.M.A.R.T. command transport (SCT) technology

6 ATA Command Set

Commands	Feature Set	ATA-8	Comments	OpCode
CHECK POWER MODE	Power Mgmt	M		E5h
DATA SET MANAGEMENT EXT	Data Set Mgmt	O		06h
DISABLE AUTOMATIC ACOUSTIC MGMT	Set Features			EFh
DISABLE DEVICE-INITIATED INTERFACE POWER-STATE TRANSITIONS	Set Features			EFh
DISABLE DMA SETUP FIS AUTO-ACTIVATE OPTIMIZATION	Set Features			EFh
DISABLE LOOK-AHEAD	Set Features			EFh
DISABLE REVERTING TO POWER-ON DEFAULTS	Set Features			EFh
DISABLE SOFTWARE SETTINGS PRESERVATION	Set Features			EFh
DISABLE WRITE CACHE	Set Features			EFh
DOWNLOAD MICROCODE	General	O		92h
ENABLE AUTOMATIC ACOUSTIC MGMT	Set Features			EFh
ENABLE DEVICE-INITIATED INTERFACE POWER-STATE TRANSITIONS	Set Features			EFh
ENABLE DMA SETUP FIS AUTO-ACTIVATE OPTIMIZATION	Set Features			EFh
ENABLE LOOK-AHEAD	Set Features			EFh
ENABLE REVERTING TO POWER-ON DEFAULTS	Set Features			EFh
ENABLE SOFTWARE SETTINGS PRESERVATION	Set Features			EFh
ENABLE WRITE CACHE	Set Features			EFh
EXECUTE DEVICE DIAGNOSTIC	General	M		90h
FLUSH CACHE	General	M		E7h
FLUSH CACHE EXT	48-bit Address	M		EAh
IDENTIFY DEVICE	General	M		ECh
IDLE	Power Mgmt	M		E3h
IDLE IMMEDIATE	Power Mgmt	M	No support for unload	E1h
INITIALIZE DEVICE PARAMETERS	General	M		91h
NOP	General	O		00h
READ BUFFER	General	O		E4H
READ DMA	Data Transfer	M		C8h
READ DMA (w/o retry)	Data Transfer	Obs		C9h
READ DMA EXT	48-bit Address	M		25h
READ FPDMA QUEUED	Data Transfer NCQ	M		60h
READ LOG DMA EXT	Gen.Purpose Logging 48-bit	O		47h
READ LOG EXT	Gen.Purpose Logging	M		2Fh
READ LONG	Data Transfer			22h
READ LONG without Retry	Data Transfer			23h

Commands	Feature Set	ATA-8	Comments	OpCode
READ MULTIPLE	Data Transfer	M		C4h
READ MULTIPLE EXT	48-bit Address	M		29h
READ NATIVE MAX ADDRESS	HPA	M		F8h
READ NATIVE MAX ADDRESS EXT	HPA	M		27h
READ SECTOR(S)	Data Transfer	M		20h
READ SECTOR(S) EXT	48-bit Address	M		24h
READ SECTOR(S) without Retry	Data Transfer			21h
READ VERIFY SECTOR(S)	General	M		40h
READ VERIFY SECTOR(S) EXT	48-bit Address	M		42h
READ VERIFY SECTORS(S) (w/o retry)	General	Obs		41h
RECALIBRATE	General	Obs		10h
SCT COMMAND / STATUS	SMART			B0h
SCT DATA TABLES: READ TABLE: (HDA) TEMPERATURE HISTORY TABLE	SMART			B0h
SCT DATA TRANSFER	SMART			B0h
SCT FEATURE CONTROL: FORCED WRITE CACHE ENABLE & DISABLE	SMART			B0h
SCT WRITE SAME	SMART		Not recommended for SSDs; can negatively affect initial performance of drive.	B0h
SECURITY DISABLE PASSWORD	Security	M		F6h
SECURITY ERASE PREPARE	Security	M		F3h
SECURITY ERASE UNIT	Security	M		F4h
SECURITY FREEZE LOCK	Security	O		F5h
SECURITY SET PASSWORD	Security	M		F1h
SECURITY UNLOCK	Security	M		F2h
SEEK	General	M		70h
SET MAX ADDRESS	HPA	M		F9h
SET MAX ADDRESS EXT	HPA	M		37h
SET MAX FREEZE LOCK	HPA	O		F9h/04h
SET MAX LOCK	HPA	O		F9h/02h
SET MAX SET PASSWORD	HPA	O		F9h/01h
SET MAX UNLOCK	HPA	O		F9h/03h
SET MULTIPLE MODE	General	M		C6h
SET TRANSFER MODE (based on value in SECTOR COUNT REGISTER)	Set Features			EFh
SLEEP	Power Mgmt	M		E6h
SMART ABORT OFFLINE ROUTINE	SMART			B0h
SMART DISABLE OPERATIONS	SMART	M		B0h/D9h
SMART ENABLE OPERATIONS	SMART	M		B0h/D8h
SMART ENABLE/DISABLE AUTOSAVE	SMART	M		B0h/D2h
SMART EXECUTE CONVEYANCE SELF-TEST ROUTINE (captive)	SMART			B0h

Commands	Feature Set	ATA-8	Comments	OpCode
SMART EXECUTE CONVEYANCE SELF-TEST ROUTINE (offline)	SMART			B0h
SMART EXECUTE EXTENDED SELF-TEST ROUTINE	SMART			B0h
SMART EXECUTE EXTENDED SELF-TEST ROUTINE (captive)	SMART			B0h
SMART EXECUTE OFFLINE IMMEDIATE	SMART	O		B0h/D4h
SMART EXECUTE OFFLINE ROUTINE	SMART			B0h
SMART EXECUTE SELECTIVE SELF-TEST ROUTINE	SMART			B0h
SMART EXECUTE SELECTIVE SELF-TEST ROUTINE (captive)	SMART			B0h
SMART EXECUTE SHORT SELF-TEST ROUTINE	SMART			B0h
SMART EXECUTE SHORT SELF-TEST ROUTINE (captive)	SMART			B0h
SMART READ DATA	SMART	O		B0h/D0h
SMART READ LOG	SMART	O		B0h/D5h
SMART READ THRESHOLD	SMART	Obs		B0h-D1h
SMART RETURN STATUS	SMART	O		B0h/DAh
SMART SAVE ATB THRESHOLDS	SMART	Obs		B0h-D3h
SMART WRITE LOG	SMART	O		B0h/D6h
STANDBY	Power Mgmt	M		E2h
STANDBY IMMEDIATE	Power Mgmt	M		E0h
WRITE BUFFER	General	O		E8h
WRITE DMA	Data Transfer	M		CAh
WRITE DMA (w/o retry)	Data Transfer	Obs		CBh
WRITE DMA EXT	48-bit Address	M		35h
WRITE DMA FUA EXT	48-bit Address	M		3Dh
WRITE FPDMA QUEUED	Data Transfer NCQ	M		61h
WRITE LOG DMA EXT	Gen.Purpose Logging	O		57h
WRITE LOG EXT	Gen.Purpose Logging	M		3Fh
WRITE LONG	Data Transfer			32h
WRITE LONG without Retry	Data Transfer			33h
WRITE MULTIPLE	Data Transfer	M		C5h
WRITE MULTIPLE EXT	48-bit Address	M		39h
WRITE MULTIPLE FUA EXT	48-bit Address	M		CEh
WRITE SECTOR(S)	Data Transfer	M		30h
WRITE SECTOR(S) (w/o retry)	Data Transfer	Obs		31h
WRITE SECTOR(S) EXT	48-bit Address	M		34h
WRITE UNCORRECTABLE EXT	General	O		45h
Key: M-Mandatory O-Optional P-Prohibited N-Not defined				

7 SMART

Table 10-1:SMART Command Set

Value (hex)	Command
00-CF	Reserved
D0	SMART read attributes
D1*	SMART read threshold
D2	SMART enable/disable attribute autosave
D3*	SMART save attribute values
D4	SMART execute off-line immediate
D5	SMART read log sector
D6	SMART write log sector
D7*	SMART write attribute threshold
D8	SMART enable operations
D9	SMART disable operations
DA	SMART return status
DC-FF	Reserved (Vendor Specific)

Table 10-2:SMART Attribute Data Structure

Byte	Description
0:1	SMART structure version number
2	First Stored Attribute Number (i.e. "1" for "Raw Read Error Rate")
3:4	Status
5	Nominal value
6	Worst value since SSD was deployed
7:12	Raw Data
13	(Reserved; for some Attributes, the 7 th "raw data" byte)
14:25	Next Stored Attribute Number (i.e. "3" for "Retired Block Count")
26:361	Next Stored Attribute Nos (max 30 collected Attributes, including above)
362	Off-line data collection status
363	Self-Test execution status byte
364:365	Total time to complete off-line data collection (in seconds)
366	(Reserved)
367	Off-line Data Collection capability
368:369	SMART capability
370	Error Logging Capability (bit 0 set = device error logging supported)
371	Next Self Test Step
372	Short Self Test routine recommended polling time (in minutes)
373	Extended Self Test routine recommended polling time (in minutes)
374	Recommended polling time for Conveyance Self Test
375:376	Time for Extended Self Test if > 255 (ie, 373 to FFh)
377:385	(Reserved)
386:510	Vendor information
511	Checksum of data structure (generated on retrieval of stored data)

8 Buy Information

Capacity	MLC Part Numbers	SLC Part Numbers
8GB	RCM008-SX1M	RCS008-SX1M
16GB	RCM016-SX1M	RCS016-SX1M
32GB	RCM032-SX1M	RCS032-SX1M
64GB	RCM064-SX1M	RCS064-SX1M
128GB	RCM128-SX1M	N

9 Product model of naming rule

